



Phoenix
Digital

MODBUS PLUG-AND-PLAY TOOLS for CONTROL NETWORKS

Phoenix Digital now provides a complete set of Modbus Communication Tools, providing higher throughput, greater flexibility, and higher reliability than ever before possible with conventional Modbus communication equipment. Phoenix Digital's family of Modbus Optical Communication Modules (OCXs) provide Multidrop Fiber Optic Communications for high reliability Modbus, Modbus/TCP, and Modbus & Ethernet networks, with On-the-Fly Modbus Multi-Master Multiplexing. Phoenix Digital's Modbus Port Expander Plus (MPE+) operates as a Modbus Multi-Master Multiplexer, Network Server, and Communication Controller... all in one. The OCXs and MPE+ are available in modular Standalone DIN-Rail/Panelmount, and 19 inch Rackmount Enclosures... with 120/220 VAC, 24 VDC, or 125 VDC power supplies. (Available with Single or Dual power supplies.)

MODBUS FIBER OPTIC MODULES. . . FEATURES

- Fiber Optic Communications. . .
Noise Immunity, Intrinsically Safe.
- Dependable Data Communications. . .
Fault Tolerant, Redundant Fiber Media.
Fault Location, On-Line Error Checking.
- Network-Wide Diagnostics. . .
Locates Faults and Traps Intermittent Faults.
- **On-the-Fly** Modbus Multi-Master Multiplexing. . .
Allows Unlimited Number of Modbus Master devices anywhere on the network.
Modbus Multi-Master Multiplexing
Transparent to Network Operation.
- Short or Long Distance. . .
6 Feet (2 meters) to 4+ Miles
(6.4 km) Apart - Multimode Operation.
Over 60 Miles (96 km) Apart -
Single Mode Operation.

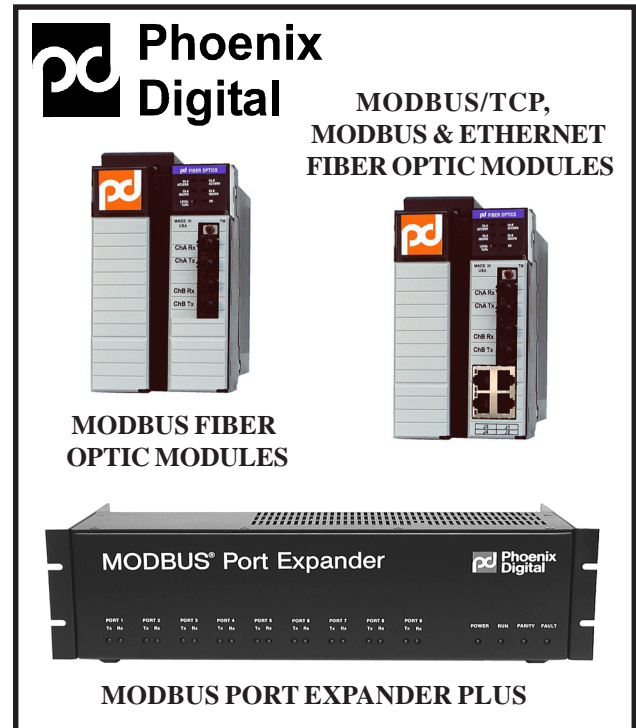

- Selectable Wavelengths. . . 850, 1300, 1550 nm.
- Selectable Fiber Optic Connector Styles. . .
ST, SC, LC, or MTRJ.
- Compatible with Both Single Mode and Multimode Fiber, and with Industrial Fiber.
- Modbus & Ethernet on Fiber. . .
Simultaneously communicate Modbus and FAST Ethernet (10/100 Mbps) on the Same Fiber Optic Network.
Each Fiber Optic Module Supports One Modbus Port (RS-232 or RS-485) and Six RJ-45, 10/100 Base-T Ethernet Ports.
Ultra-High Speed, Redundant, Self-Healing Switch-Over in Ring Configurations.
Multidrop 100+ Fiber Optic Modules.
Transparent Management for all Ethernet Protocols, including **Modbus/TCP**.
Phoenix Digital Proprietary Priority Queuing System (PQS) Insures Ultra-High Throughput.
- **UL Class I, Division 2 Rating.**

MODBUS OPTICAL COMMUNICATION MODULES

DESCRIPTION

Phoenix Digital's family of Optical Communication Modules for Modbus networks provides the most advanced, comprehensive, fiber optic communication capabilities on the market today. Phoenix Digital's fiber modules provide optical communication media, transparent to the communication protocol and configurable for distribution by the user in multidrop ring, bus, star, tree, or point-to-point network installations. Phoenix Digital's Modbus fiber optic modules enable On-the-Fly, Network-Wide Multi-Master Multiplexing, transparent to the operation of the network at-large. In addition, Phoenix Digital's Modbus fiber modules will allow simultaneous, transparent communication of both Modbus (RS-232/485) and FAST Ethernet (10/100 Mbps) data on the same physical fiber network. Phoenix Digital's fiber optic modules provide continuous on-line error checking for jitter, pulse-width distortion, and carrier symmetry. All of this, together with comprehensive self-test diagnostics, optimizes the overall integrity of Modbus, Modbus/TCP, and Modbus & Ethernet communication networks at-large, providing Dependable Data Communications.

Optical communication network options include features not found in even the most expensive communication network installations:

- On-line Diagnostic Monitoring.
- Self-Healing Communication Recovery.
- Locates Fault Conditions.
- Traps Intermittent Fault Conditions.
- User Access to Network-Wide Diagnostics.
- On-the-Fly, Modbus Multi-Master Multiplexing Allows Unlimited Number of Modbus Master devices anywhere on the network, Transparent to Network Operation.

- Multidrop 100+ Fiber Modules on a Single Bus, Ring, or Star Network.
- Overcomes PLC Scan Time Limitations with High Speed, Self-Healing Switch-Over in Ring Configurations.
- High Speed, Self-Healing Switch-Over provides Ultra-Fast Recovery of Control Networks.
- Modbus/TCP Fiber Modules Support Six RJ-45, 10/100 Base-T Transparently Managed and Switched Ethernet Ports on each module.
- Modbus & Ethernet Fiber Modules Support one Modbus Port (RS-232 or RS-485) and Six RJ-45, 10/100 Base-T Transparently Managed and Switched Ethernet Ports on each module, compatible with ALL ETHERNET PROTOCOLS.
- Phoenix Digital's Proprietary Priority Queuing System (PQS) Manages Overall Communication Bandwidth and Network Latency to Insure Priority Access and Even Faster Thruput for Critical Control Nodes on the Network.
- Supports Auto-Negotiation and Auto-MDI/MDIX Crossover, for Modbus/TCP and Modbus & Ethernet Plug-and-Play Connectivity.
- UL Class I, Division 2 Rating.
- Wavelength Selection
- Extended Communication Distances

Phoenix Digital's fiber optic modules may be used together in the same physical network to connect Programmable Logic Controllers (PLCs), Distributed Control Systems (DCS), Host Computers, Workstations, Operator Interface Panels, Modbus Port Expanders, etc.

OPERATION

MODBUS/TCP... Phoenix Digital's Modbus/TCP fiber optic modules are fully compatible with ALL Ethernet network protocols, including Modbus over Ethernet communications, operating at either 10 or 100 Mbps.

MODBUS & ETHERNET... Phoenix Digital's Modbus & Ethernet fiber optic modules enable the user to simultaneously connect and communicate between Modbus devices (RS-232 or RS-485) and Ethernet devices (10 or 100 Mbps) on the same physical fiber optic network. One fiber optic cable plant, with one network topology, supports both networks simultaneously, with unlimited expansion, total transparency, and no changes to the hardware or software of either network. Phoenix Digital's fiber optic modules will automatically manage flow control, network-wide, to insure the Modbus and Ethernet networks remain independent and isolated, while sharing the same fiber optic media on ring, bus, and/or star network topologies.

MODBUS MULTI-MASTER

MULTIPLEXING, ON-THE-FLY... Phoenix Digital's Modbus and Modbus & Ethernet fiber optic modules enables multiple Modbus masters to communicate on the same Modbus network, by providing virtual Modbus Multi-Master Multiplexing, On-the-Fly. This feature enables the user to install an unlimited number of Modbus Master devices anywhere on the fiber optic network, and let the fiber modules manage and multiplex Master/Slave communications, network-wide. This feature is totally transparent to the Modbus network at-large, does not rely on any type of special Modbus function codes or software intervention by the user, and requires no changes to either the hardware or software of the Modbus network.

Phoenix Digital's On-the-Fly, Modbus Multi-Master Multiplexing enables the user to connect and locate any number of Host Computers,

Operator Interfaces, etc., anywhere on the network, providing unlimited Host access, and Hot Back-Up Redundancy for Host devices.

FAULT MANAGEMENT... Phoenix Digital's fiber optic modules provide fault tolerant, redundant, self-healing communications through diagnostic monitoring of the communication signal waveforms at each node on the network, and ultra-high speed detection and isolation of points of communication failure anywhere on the network. The fiber modules self-heal around communication failures in ring, bus, star, tree, or point-to-point network configurations. They automatically redirect network traffic around points of failure until the failure conditions are corrected, and then automatically restore the communication network to its original traffic patterns. Thus, communication continuity is unconditionally maintained by the fiber modules in the event of either node or media failure, enabling maintenance personnel to splice/terminate/replace fiber media, add/delete nodes, etc. on-line, without disrupting network communications! In addition, Phoenix Digital's fiber optic modules provide diagnostic outputs to locate network fault conditions, providing real time, on-line diagnostic monitoring of the communication network at-large. All of this is transparent to the operation of Modbus, Modbus/TCP, and Modbus & Ethernet communication networks.

INTERACTIVE DIAGNOSTICS... Phoenix Digital's fiber optic modules provide advanced, system-level interactive diagnostics. These diagnostics may be used to assist in troubleshooting a wide variety of different types of network problems:

- Detect and Locate Fault Conditions Throughout the Network
- Trap-and-Hold, and Locate Intermittent Communication Failures
- Verify Fault Management and Overall Network Integrity

These advanced diagnostics provide the user with a powerful set of tools, greatly simplifying network start-up and on-line maintenance of Modbus, Modbus/TCP, and Modbus & Ethernet communication networks.

FIBER MEDIA COMPATIBILITY...

Phoenix Digital's fiber optic modules provide optional wavelength selection for extended distance applications, and for universal compatibility with all types of fiber optic cable. The economical 850 nanometer wavelength may be selected for data communication networks with less than 6,600 feet (2.0 kilometers) between nodes. The higher performance 1300 nanometer multimode wavelength may be selected for longer distance applications, extending communication distances between nodes to over 4+ miles (6.4 kilometers). (Consult the factory for longer distance multimode fiber optic networks, using Phoenix Digital's High Bandwidth fiber optic cable.) The 1300 nanometer single mode wavelength may be selected for extended distance applications, extending communication distances between nodes to over 32 miles (51 kilometers). The 1550 nanometer single mode wavelength may be selected for extremely long distance applications, extending communication distances between Modbus, Modbus/TCP, and Modbus & Ethernet nodes to over 60 miles (96 kilometers)!

INSTALLATION

Phoenix Digital's Fast Ethernet Optical Communication Modules are available in rugged, modular, industrial enclosures, for DIN-Rail or Panelmount installation, with integral 120/220 VAC, 24 VDC, and 125 VDC power supply options. (Dual, Redundant power supply options are also available.) Modbus devices (RS-232/485) may be cabled directly to Modbus and Modbus & Ethernet fiber optic modules

using 9 conductor wire cable with 9 pin, Micro D Subminiature connectors. Ethernet devices, including Modbus/TCP, may be cabled directly to Modbus/TCP and Modbus & Ethernet fiber optic modules using twisted pair wire cable with standard RJ-45 connectors (10/100 Base-T).

Phoenix Digital's fiber optic modules may be interconnected on the fiber optic network in an active bus or fault tolerant ring configuration, using either multimode or single mode fiber optic cable. Fiber optic Channel A and B inputs and outputs may be interconnected sequentially from fiber module to fiber module to create a bi-directional, active bus. This configuration may be made fault tolerant by cross-connecting the unused fiber optic channels on the fiber modules on either end of the active bus, to form a ring. (See Figures on pages 9 thru 12.) This effectively transforms it into a fault tolerant, redundant, self-healing, counter-rotating ring network for Modbus, Modbus/TCP, and Modbus & Ethernet networks, without requiring any further action by the user.

Phoenix Digital's Modbus, Modbus/TCP, and Modbus & Ethernet fiber optic modules can also be connected transparently to Ethernet Hubs, Switches, Routers, etc., to provide **Total Enterprise Connectivity...** Integrating Multidrop Bus, Ring, Star, and Tree Network Topologies.

MODBUS PORT EXPANDER PLUS... FEATURES

- Multi-Master Multiplexer. . .
 Multiplex up to 8 Modbus Masters with a Single MPE+.
 Cascade multiple MPE+ units for additional Modbus Master Multiplexing capability.
 - Self Teaching, Real Time Database. . .
 Instantaneous Modbus Response.
 No-Wait Screen Updating.
 - Hot Standby, Fail Safe Operation.
 - Peer-to-Peer Modbus Communications. . .
 Communicate directly between Modbus Slave devices.
 - Host-to-Host Modbus Communications. . .
 Communicate directly between Modbus Host devices.
 - Interfaces Dissimilar Modbus Devices. . .
 On-the-Fly Conversion of all Modbus Communication Parameters, Including ASCII/RTU.
- Multiple Modbus Master Multiplexing...
 with as many as 8 Masters multiplexed on a single Modbus network, and many more when cascading multiple MPE+ units.
 - Self Teaching, Real Time Database maintained by the MPE+, providing high speed thruput and instantaneous screen updates.
 - Hot Standby, Fail Safe Operation with Multiple MPE+ units.
 - Peer-to-Peer Modbus Communication between Slave Devices. (PLCs, etc.)
 - Host-to-Host Modbus Communication between Host Devices. (Computers, Operator Interface, etc.)
 - Conversion of Modbus Communication Parameters On-the-Fly... Including ASCII/RTU, Baud Rate, Parity, etc.
 - Robust Diagnostics Including Message Counters, Error Detectors, Error Counters, Loop Back Test, Software Validity Test, Memory Test, etc.
 - Modbus Communication Ports Available with RS-232, 422, or 485 Drivers.
 - Handshaking for compatibililty with Modbus Communication Modems.

DESCRIPTION

The Modbus Port Expander Plus provides a wide variety of different Modbus communication tools, for solving the most difficult Modbus communication problems. The MPE+ enables users to overcome virtually all types of performance and compatibility limitations in Modbus communication networks.

MPE+ primary features include:

- 100 % Modbus Compatibility.
- 9 Modbus Ports, Individually Configurable for Master or Slave Devices, at any Baud Rate from 300 baud to 19.2 Kbaud.

Phoenix Digital's MPE+ units may be used to interconnect all types of dissimilar Modbus compatible equipment, in the same physical network, providing protocol compatibility throughout the network.

OPERATION

The Modbus Port Expander (MPE+) is fully compatible with the Modbus protocol, and functions with all Modbus compatible devices. The MPE+ provides 9 communication ports, each individually configurable for Master/Slave orientation, ASCII/RTU mode, baud rate, parity, stop bits, time-out, and modem interface. The MPE+ performs conversion of all communication parameters between ports, on-the-fly.

The MPE+ may be used as a Modbus Master Multiplexer, multiplexing as many as 8 Modbus master devices onto one Modbus network. (See Figure on Page 9.) If more Modbus Masters are required then multiple MPE+ units may be cascaded together, providing virtually unlimited Master multiplexing capability.

The MPE+ incorporates Phoenix Digital's exclusive self teaching, real time database, for accelerated Modbus communication thruput. The MPE+ teaches itself Slave address locations (scan list) for its database by memorizing read requests from Master (Host) devices. The MPE+ creates a database image table from this scan list, which it will continually refresh with the latest Slave coil and register information. Master devices receive data instantaneously from this database, thereby eliminating communication and Slave (PLC, etc.) latency times. Thus, the MPE+ drastically reduces the response time to Master devices. The MPE+ automatically self-prioritizes the database update frequency to update data which is most frequently requested by Master devices, at the the highest possible rate. The user may also manually set the database update frequency to allow application of specific network tuning of the MPE+ database and pass-thru features.

The MPE+ enables Slave devices (PLCs, etc.) to communicate directly with each other via a Peer-to-Peer mailbox architecture. Within each Slave the user simply allocates two mailbox areas in register memory, one for incoming mail and the other for outgoing mail. Incoming mailboxes store data communicated from other Slave devices while outgoing mailboxes store data to be communicated to other Slave devices. The MPE+ continuously reads (polls) the data in the individual outgoing Slave mailboxes and writes (broadcasts) this data to specified Slave incoming mailboxes. Reading and writing of mailbox data by the MPE+ occurs without any special type of programming, and is 100%

transparent to Slave control functions. The MPE+ also provides Host-to-Host communication between multiple Modbus Master devices. A "virtual" Slave database is created within the MPE+ for Master (Host) device access, and all references to the designated "virtual" Slave node address will access this database. Data may be read or written to this database via normal Modbus coil and register read/write commands. The powerful combination of Peer-to-Peer and Host-to-Host communication allows any Modbus device to communicate directly with any other device for maximum effective thruput.

The MPE+ automatically converts dissimilar communication parameters such as low and high baud rates, ASCII and RTU data formats, etc., on-the-fly. It also may be ordered with one or more Modbus ports configured for RS-232, RS-422, or RS-485 communication.

The MPE+ provides expanded Modbus diagnostic and troubleshooting capabilities, which are not available with any other Modbus communication device on the market today. The MPE+ enables Modbus users to examine and display individual Slave device communication status information by directly reading Slave communication registers. In addition, the MPE+ provides a communication loopback test for confirmation of valid Modbus communications. The MPE+ also provides self-diagnostics including power monitoring, memory parity, processor fault detection, pass-thru relays for fault tolerant network communications, and fail safe control for hot standby operation.

MPE+ INSTALLATION

The MPE+ is provided in a modular Industrial Enclosure. It includes provisions for panelmounting, mounting on a standard 19" rack, or desk top installation.

SPECIFICATIONS

MODBUS FIBER OPTIC MODULES :

Fiber Optic Cable Type	: Multimode or Single Mode
Mating Connector	: ST, SC, MTRJ, LC
Transmit Launch Power	: -15 dBm (Typical, Multimode); -18 dBm (Single Mode)
Receive Sensitivity	: -32 dBm
Power Supply	: 120/220 VAC, 24 VDC, or 125 VDC.... 8 to 10 Watts
Environmental	
Operating Temperature	: 0° to 60° C (32° to 140° F)
Storage Temperature	: -40° to 85° C (-40° to 185° F)
Relative Humidity	: 0 to 95% RH, noncondensing
Dimensions (DIN-Rail, Panelmount)	: 6.10" H x 3.10" W x 5.50" D (15.49cm H x 7.87cm W x 13.97cm D)
Hazardous Location Approval	: UL and UL/C Class I, Div. 2 Groups A, B, C, D (US and Canadian UL Mark for use in Class I, Div. 2 Groups A, B, C, and D Hazardous Locations.)
European Union Directives	: CE

MODBUS PORT EXPANDER PLUS :

Mounting	: Panelmount, 19" Rackmount, or Desk Top
Connectors	: 25-Pin, Sub-D (female)
Power Supply	: 120/220 VAC, 24 VDC, or 125 VDC.... 30 Watts
Diagnostic Indicators	: Port - Two per port (Transmit, Receive) : System - Power, Run, Parity, Fault
Environmental	
Operating Temperature	: 0° to 60° C (32° to 140° F)
Storage Temperature	: -40° to 85° C (-40° to 185° F)
Relative Humidity	: 0 to 95% RH, non-condensing
Dimensions	: 5.25" H x 19.00" W x 7.90" D (13.34cm H x 48.26cm W x 20.07cm D)

ORDERING INFORMATION

Description

OCX-MOD ⁽¹⁾	Fiber Optic Module for Modbus Networks (RS-232).
OCX-ETF ⁽¹⁾	Fiber Optic Module for Modbus/TCP Networks (10/100 Mbps).
OCX-EMOD ⁽¹⁾	Fiber Optic Module for Modbus (RS-232/485) & Ethernet (10/100 Mbps) Networks (ALL Protocols), Simultaneous Communication.
OCM-CBL-A1-10	10/100 Base-T OCX Interconnect Cable. (10 ft./3 meter length)
OCX-CBL-MOD ⁽²⁾	Modbus (RS-232/485) Interconnect Cable Adapter. (One end 9 pin Micro D Subminiature connector (male pins), one end 9 pin Standard D Subminiature connector (female pins); 18 inches/.5 meter length)

MPE+ ⁽²⁾ MODBUS PORT EXPANDER PLUS (9 RS-232 Modbus Ports)

- (1) Add suffix “-85” for the 850 nm Multimode Wavelength. (12,000 ft/3,650 meters between nodes)
Add suffix “-13” for the 1300 nm Multimode or Single Mode Wavelength. (6 mi/10 km between nodes, multimode; 32 mi/51 km, single mode operation)
Add suffix “-15” for the 1550 nm Single Mode Wavelength. (60 mi/96 km between nodes)
Add suffix “-R” for DIN-Rail, Panelmount Module Enclosure.
Add suffix “-D” for Real Time Diagnostic Option. (Required for UL and UL/C Class I, Division 2 Rating.)
Add suffix “-ST” for ST Fiber Optic Connector Style.
Add suffix “-SC” for SC Fiber Optic Connector Style.
Add suffix “-LC” for LC Fiber Optic Connector Style. (Available for the 1300 nm and 1550 nm optical wavelengths only.)
Add suffix “-MT” for MTRJ Fiber Optic Connector Style. (Available for all optical wavelengths except the 1550 nm wavelength.)
Add suffix “-24V” for 24 VDC Operation. (“-R24V” for Redundant 24 VDC Power Supply Operation.)
Add suffix “-125V” for 125 VDC Operation. (“-R125V” for Redundant 125 VDC Power Supply Operation.)
Add suffix “-ACV” for 120/220 VAC Operation. (“-RACV” for Redundant 120/220 VAC Power Supply Operation.)
Add suffix “-xA1” to OCX-ETF and OCX-EMOD modules for 10/100 Base-T Operation, where “x” specifies the number of 10/100 Base-T ports available on the module. (x = 1 thru 6)
Add suffix “-EXT” to OCX-ETF and OCX-EMOD modules, for Networks with 10 or more fiber optic modules.
Add suffix “-485” to OCX-MOD and OCX-EMOD modules, for RS-485 Modbus communications.
Add suffix “-FD” for Full Duplex, Point-to-Point Communication.
Add suffix “-MAS” to OCX-MOD and OCX-EMOD modules, for On-the-Fly, Network-Wide, Modbus Multi-Master Multiplexing.
Add suffix “-SM” for Single Mode Operation. (Available with the 1300 Nanometer Wavelength and ST, SC, LC, or MTRJ Fiber Optic Connectors; or with the 1550 Nanometer Wavelength and ST, SC, or LC Fiber Optic Connectors.)
Add suffix “-10” to OCX-CBL-MOD cables for 10 ft./3 meter length.
- (2) Add suffix “-24V” for 24 VDC Operation. (“-R24V” for Redundant 24 VDC Power Supply Operation.)
Add suffix “-125V” for 125 VDC Operation. (“-R125V” for Redundant 125 VDC Power Supply Operation.)
Add suffix “-ACV” for 120/220 VAC Operation. (“-RACV” for Redundant 120/220 VAC Power Supply Operation.)
Add suffix “-422/x” for RS-422 Modbus communications. (Specify “x” for Number of RS-422 Ports, where x = 1 thru 9.)
Add suffix “-485/x” for RS-485 Modbus communications. (Specify “x” for Number of RS-485 Ports, where x = 1 thru 9.)

Consult the factory for additional information on fiber optic modules for other Open Standard Networks (**FAST ETHERNET**... among others); other Open and Proprietary PLC and Process Computer Networks; Other Fiber Optic Module Package Styles (19 inch Rackmount/Panelmount, Plug-In modules, etc.); and Industrial Fiber Optic Cable.

**FIBER OPTIC MODBUS (RS-232/485)
REDUNDANT, DUAL MEDIA
RING CONFIGURATION (FAULT TOLERANT),
WITH MODBUS PORT EXPANDER PLUS**

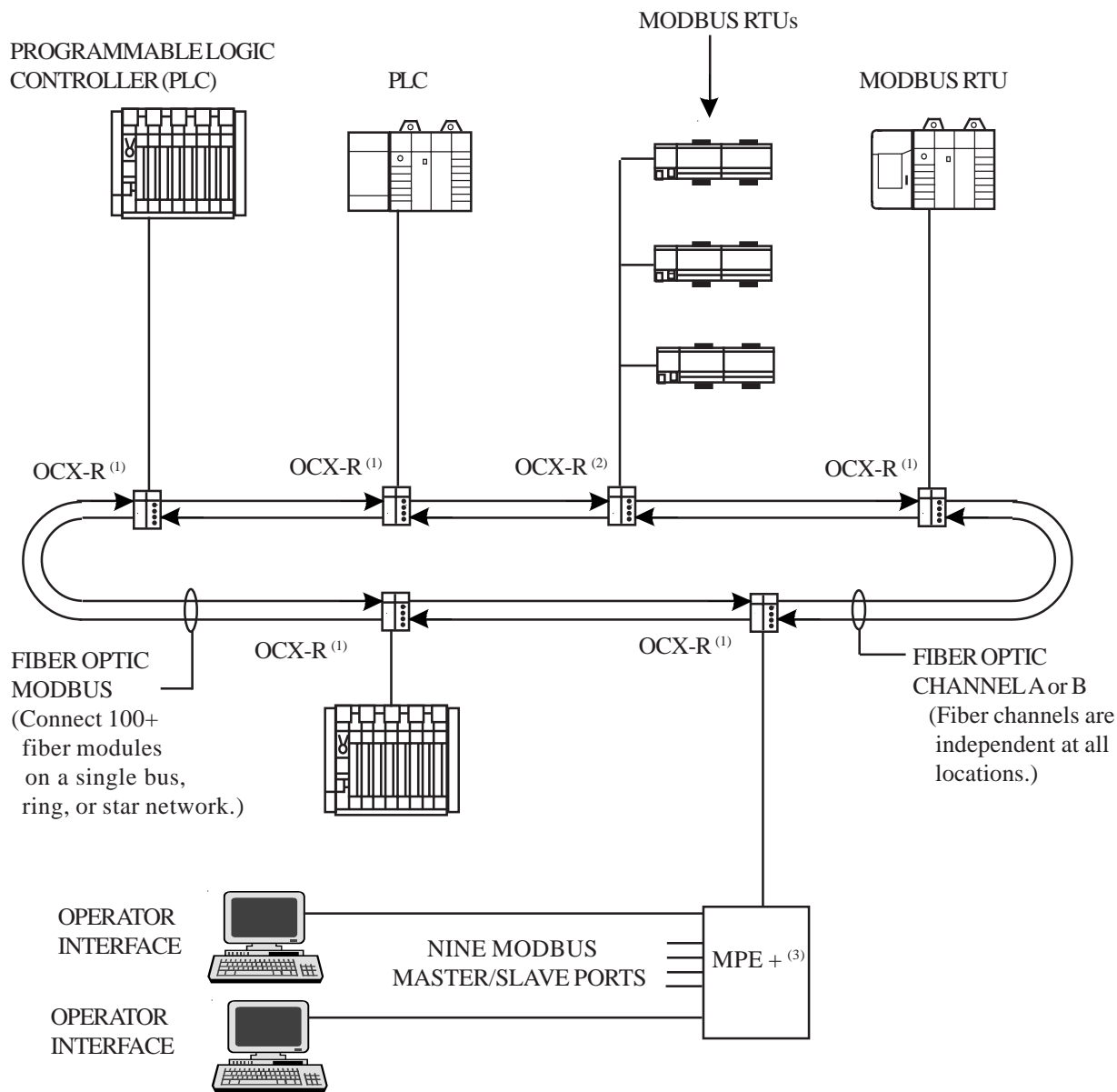

- (1) OPTICAL COMMUNICATION MODULE
MODEL # OCX-MOD-85-R-D-ST-ACV
- (2) OPTICAL COMMUNICATION MODULE
MODEL # OCX-MOD-85-R-D-ST-ACV-485

- (3) MODBUS PORT EXPANDER PLUS
MODEL # MPE + - ACV

**TYPICAL REDUNDANT, FAULT TOLERANT
FIBER OPTIC MODBUS INSTALLATION CONFIGURATION**

**FIBER OPTIC MODBUS (RS-232/485)
REDUNDANT, DUAL MEDIA
RING CONFIGURATION (FAULT TOLERANT),
WITH ON-THE-FLY MULTI-MASTER MULTIPLEXING**

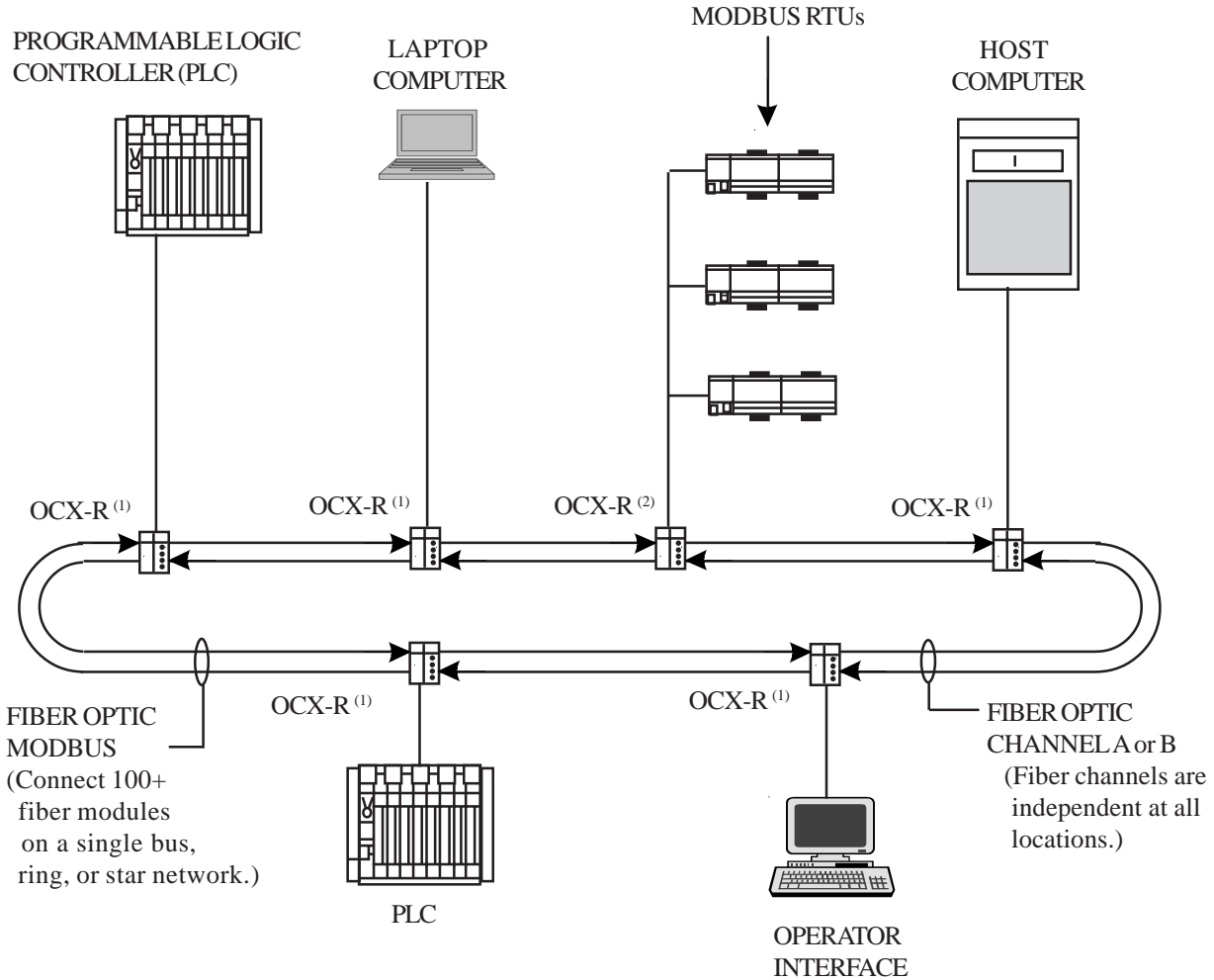

- (1) OPTICAL COMMUNICATION MODULE
MODEL # OCX-MOD-85-R-D-ST-ACV-MAS
- (2) OPTICAL COMMUNICATION MODULE
MODEL # OCX-MOD-85-R-D-ST-ACV-MAS-485

**TYPICAL REDUNDANT, FAULT TOLERANT
FIBER OPTIC MODBUS INSTALLATION CONFIGURATION,
WITH ON-THE-FLY MULTI-MASTER MULTIPLEXING
(UL CLASS I, DIVISION 2 RATING FOR HAZARDOUS LOCATIONS)**

**FIBER OPTIC MODBUS/TCP (10/100 Mbps),
REDUNDANT, DUAL MEDIA
RING CONFIGURATION
(FAULT TOLERANT)**

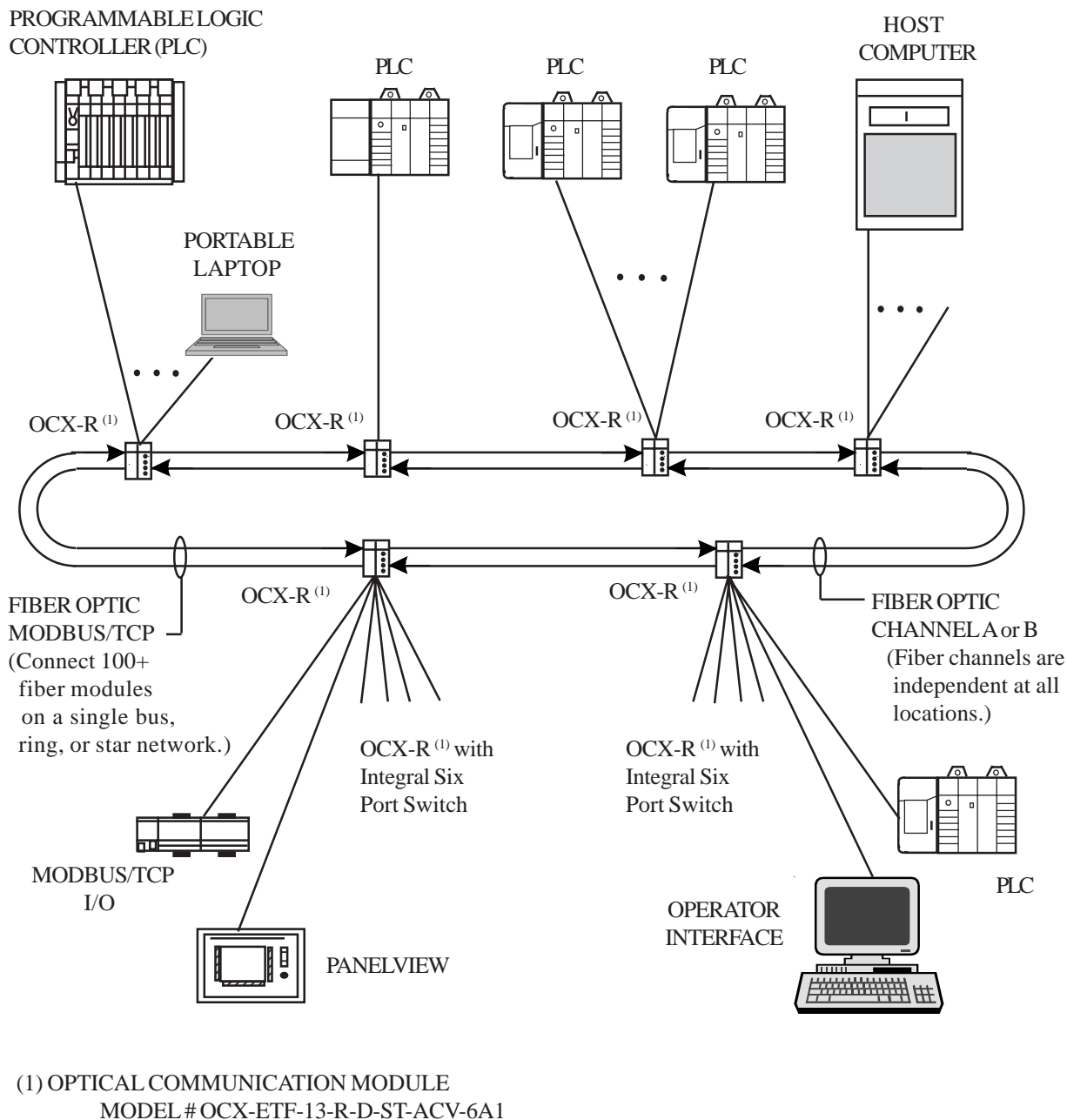

**TYPICAL REDUNDANT, FAULT TOLERANT
FIBER OPTIC MODBUS/TCP INSTALLATION CONFIGURATION
(UL CLASS I, DIVISION 2 RATING FOR HAZARDOUS LOCATIONS)**

**FIBER OPTIC MODBUS (RS-232/485) & ETHERNET (10/100 Mbps)
REDUNDANT, DUAL MEDIA
RING CONFIGURATION (FAULT TOLERANT),
WITH ON-THE-FLY MULTI-MASTER MULTIPLEXING**

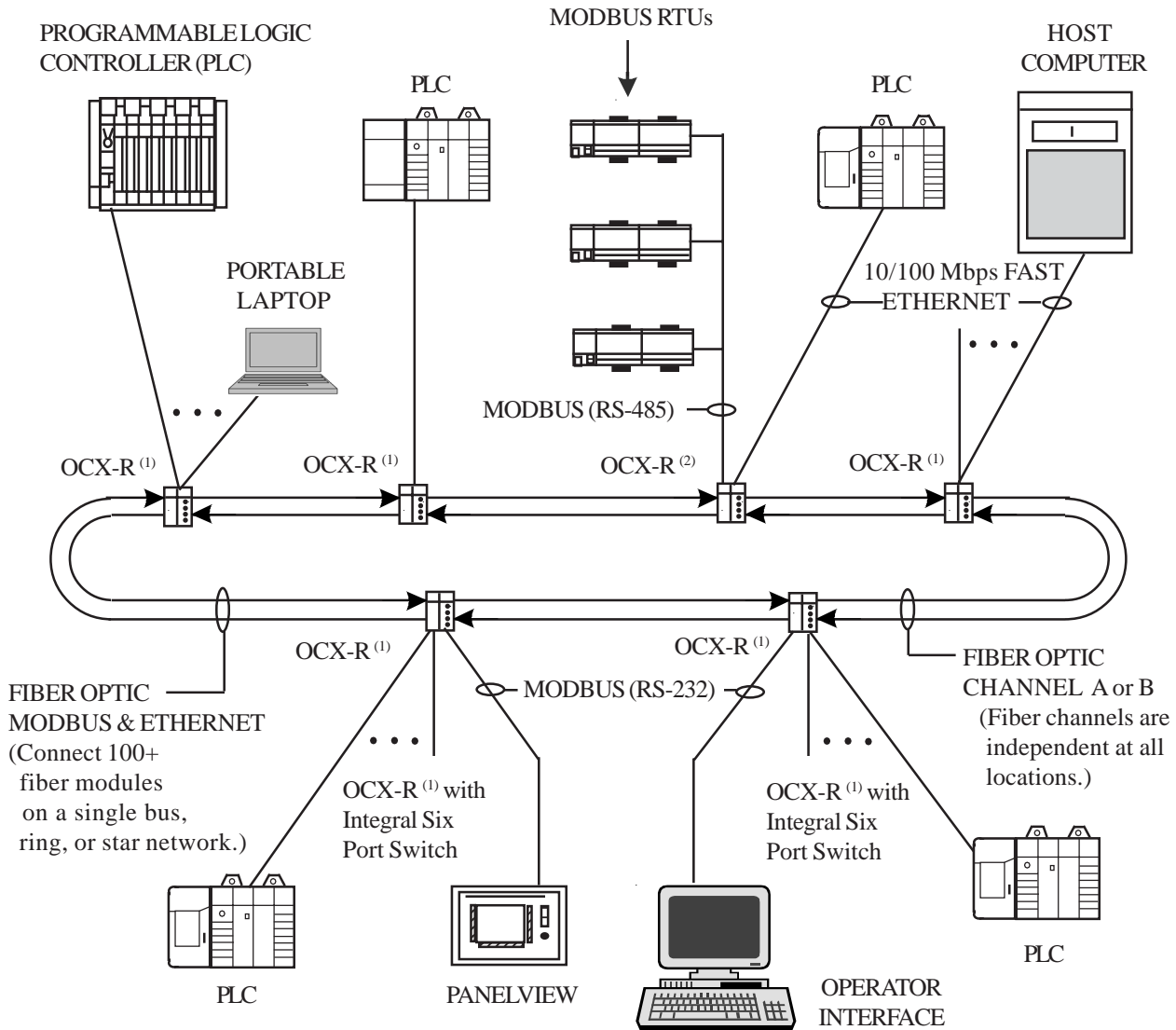

(1) OPTICAL COMMUNICATION MODULE
MODEL # OCX-EMOD-13-R-D-ST-ACV-6A1-MAS

(2) OPTICAL COMMUNICATION MODULE
MODEL # OCX-EMOD-13-R-D-ST-ACV-6A1-485-MAS



7650 East Evans Rd., Bldg. A
Scottsdale, AZ 85260
(480) 483-7393 Phone
(480) 483-7391 Fax
email: phxdigital@aol.com

internet: <http://www.phoenixdigitalcorp.com>